

Surname	Centre Number	Candidate Number
First name(s)		0

**GCSE**

3300U50-1



A24-3300U50-1

MONDAY, 11 NOVEMBER 2024 – MORNING

MATHEMATICS
UNIT 1: NON-CALCULATOR
HIGHER TIER

1 hour 45 minutes

ADDITIONAL MATERIALS

The use of a calculator is not permitted in this examination.
 A ruler, protractor and a pair of compasses may be required.

INSTRUCTIONS TO CANDIDATES

Use black ink or black ball-point pen. Do not use gel pen or correction fluid.

You may use a pencil for graphs and diagrams only.

Write your name, centre number and candidate number in the spaces at the top of this page.

Answer **all** questions.

Write your answers in the spaces provided in this booklet.
 If you run out of space, use the additional page(s) at the back of the booklet, taking care to number the question(s) correctly.

Take π as 3.14.

INFORMATION FOR CANDIDATES

You should give details of your method of solution when appropriate.

Unless stated, diagrams are not drawn to scale.

Scale drawing solutions will not be acceptable where you are asked to calculate.

The number of marks is given in brackets at the end of each question or part-question.

In question 2, the assessment will take into account the quality of your linguistic and mathematical organisation, communication and accuracy in writing.

For Examiner's use only		
Question	Maximum Mark	Mark Awarded
1.	4	
2.	7	
3.	3	
4.	6	
5.	2	
6.	5	
7.	7	
8.	3	
9.	4	
10.	5	
11.	5	
12.	6	
13.	3	
14.	3	
15.	4	
16.	4	
17.	3	
18.	6	
Total	80	



NOV243300U50101

Formula List – Higher Tier

Area of trapezium = $\frac{1}{2}(a + b)h$

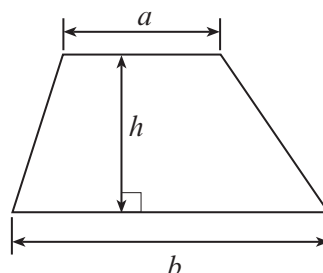

Volume of prism = area of cross-section \times length

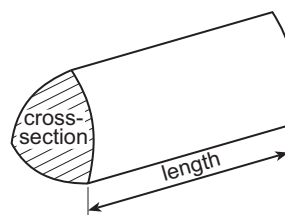

Volume of sphere = $\frac{4}{3}\pi r^3$

Surface area of sphere = $4\pi r^2$

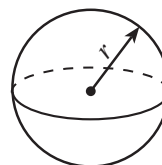

Volume of cone = $\frac{1}{3}\pi r^2 h$

Curved surface area of cone = $\pi r l$

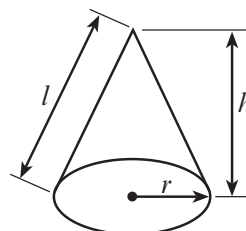

In any triangle ABC

Sine rule $\frac{a}{\sin A} = \frac{b}{\sin B} = \frac{c}{\sin C}$

Cosine rule $a^2 = b^2 + c^2 - 2bc \cos A$

Area of triangle = $\frac{1}{2}ab \sin C$

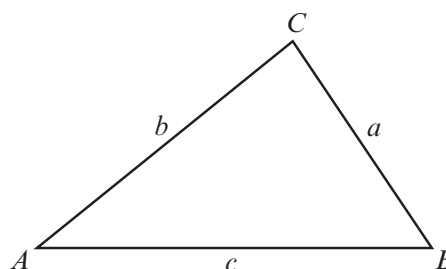

The Quadratic Equation

The solutions of $ax^2 + bx + c = 0$ where $a \neq 0$ are given by $x = \frac{-b \pm \sqrt{b^2 - 4ac}}{2a}$

Annual Equivalent Rate (AER)

AER, as a decimal, is calculated using the formula $\left(1 + \frac{i}{n}\right)^n - 1$, where i is the nominal interest rate per annum as a decimal and n is the number of compounding periods per annum.



1. The table below shows some of the values of $y = 2x^2 + x + 3$ for values of x from -2 to 3 .

x	-2	-1	0	1	2	3
$y = 2x^2 + x + 3$		4	3	6		24

(a) Complete the table by finding the values of y for $x = -2$ and for $x = 2$. [2]

.....

.....

.....

.....

(b) On the graph paper below, draw the graph of $y = 2x^2 + x + 3$ for values of x from -2 to 3 . [2]

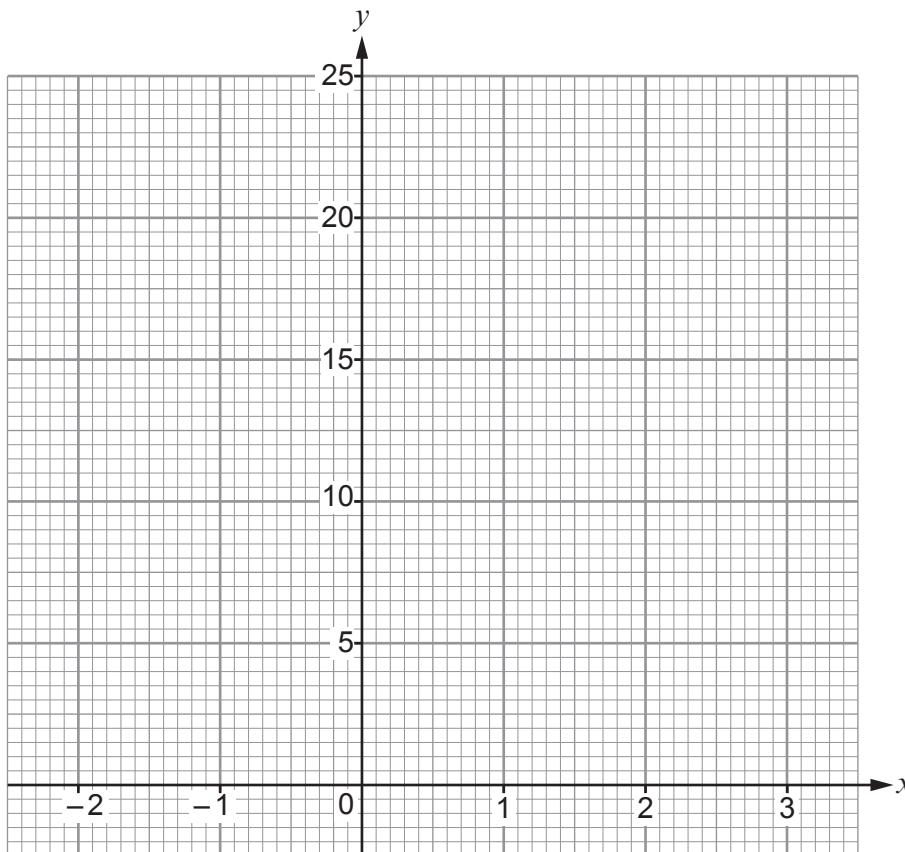

3300U501
03



Examiner
only

4. A cyclist travels for 2 hours at an average speed of x miles per hour. She then travels for a further 3 hours at an average speed of $(x + 6)$ miles per hour. She travels a total distance of 78 miles.

Form an equation, in terms of x , to represent the total distance she travels. Solve your equation and use your solution to complete the statements below. [6]

.....

.....

.....

.....

.....

.....

.....

.....

.....

.....

.....

.....

.....

.....

.....

.....

.....

.....

.....

.....

.....

.....

.....

First, the cyclist travels for 2 hours at an average speed of miles per hour.

Then, she travels for a further 3 hours at an average speed of miles per hour.



5. The two shapes below are mathematically similar.

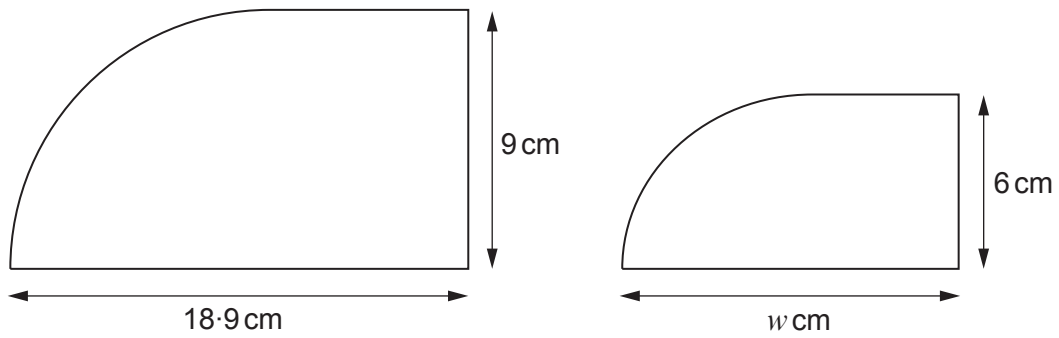

Diagrams not drawn to scale

Calculate the value of w .

[2]

.....

.....

.....

.....

.....

.....

.....

.....

.....

.....



6. Evan and Jane each shoot one arrow at a target.
The probability that Evan hits the centre of the target is 0.4.
The probability that Jane hits the centre of the target is 0.45.

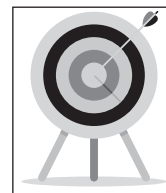

(a) Complete the tree diagram below.

[3]

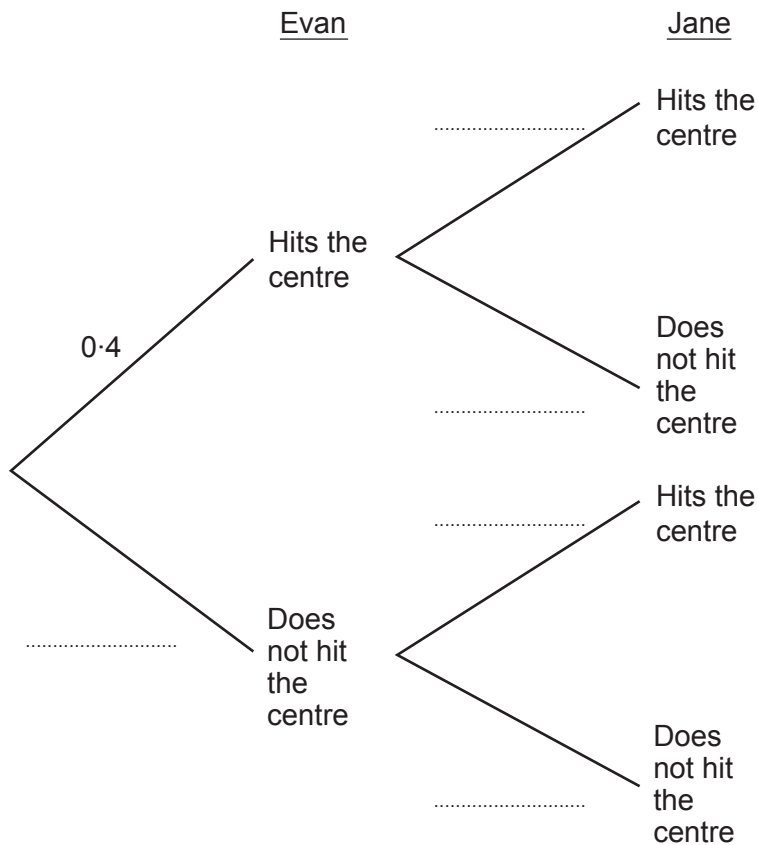

(b) Find the probability that Evan and Jane both hit the centre of the target.

[2]

.....

.....

.....

.....

.....

.....

.....



7. A rectangle has length $(x + 5)$ cm and width $(x + 3)$ cm. The area of the rectangle is 120 cm^2 .

(a) Show that $x^2 + 8x - 105 = 0$. [2]

.....
.....
.....
.....
.....
.....

(b) Factorise $x^2 + 8x - 105$, and hence solve $x^2 + 8x - 105 = 0$. [3]

.....
.....
.....
.....
.....
.....

(c) Use your solutions from part (b) to find the dimensions of the rectangle. You must justify any decisions that you make. [2]

.....
.....
.....
.....
.....

Length of rectangle = cm

Width of rectangle = cm



Examiner
only

8. Convert 3.2×10^4 metres into **miles**.

[3]

.....

.....

.....

.....

.....

.....

.....

.....

.....

.....

.....

.....

.....

.....

.....

3.2×10^4 metres is miles



Examiner only

9. A, B, C and D are points on the circumference of a circle with centre O .

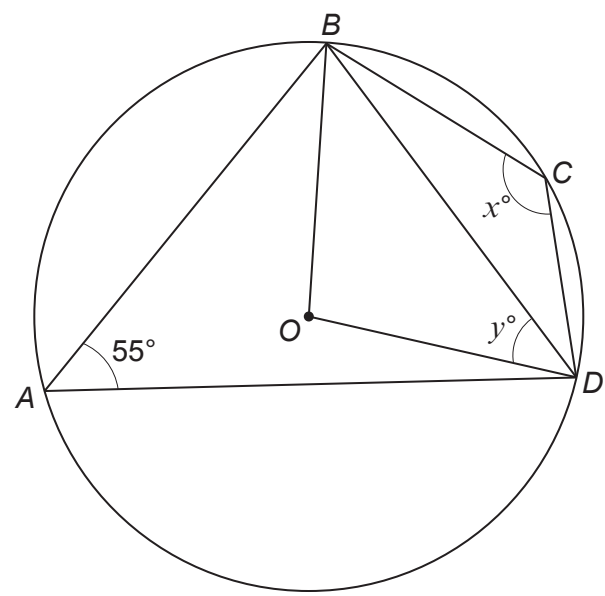

Diagram not drawn to scale

(a) Calculate the value of x .
Circle your answer. [1]

- 55°
- 70°
- 110°
- 125°
- 135°

.....

(b) Calculate the value of y . [3]

.....



Examiner only

10. (a) On the graph paper below, draw the region that satisfies all of the following conditions.

$$y - x \leq 1$$

$$y \geq \frac{x}{2}$$

$$x \leq 3$$

Clearly indicate the region that represents your answer. [3]

.....

.....

.....

.....

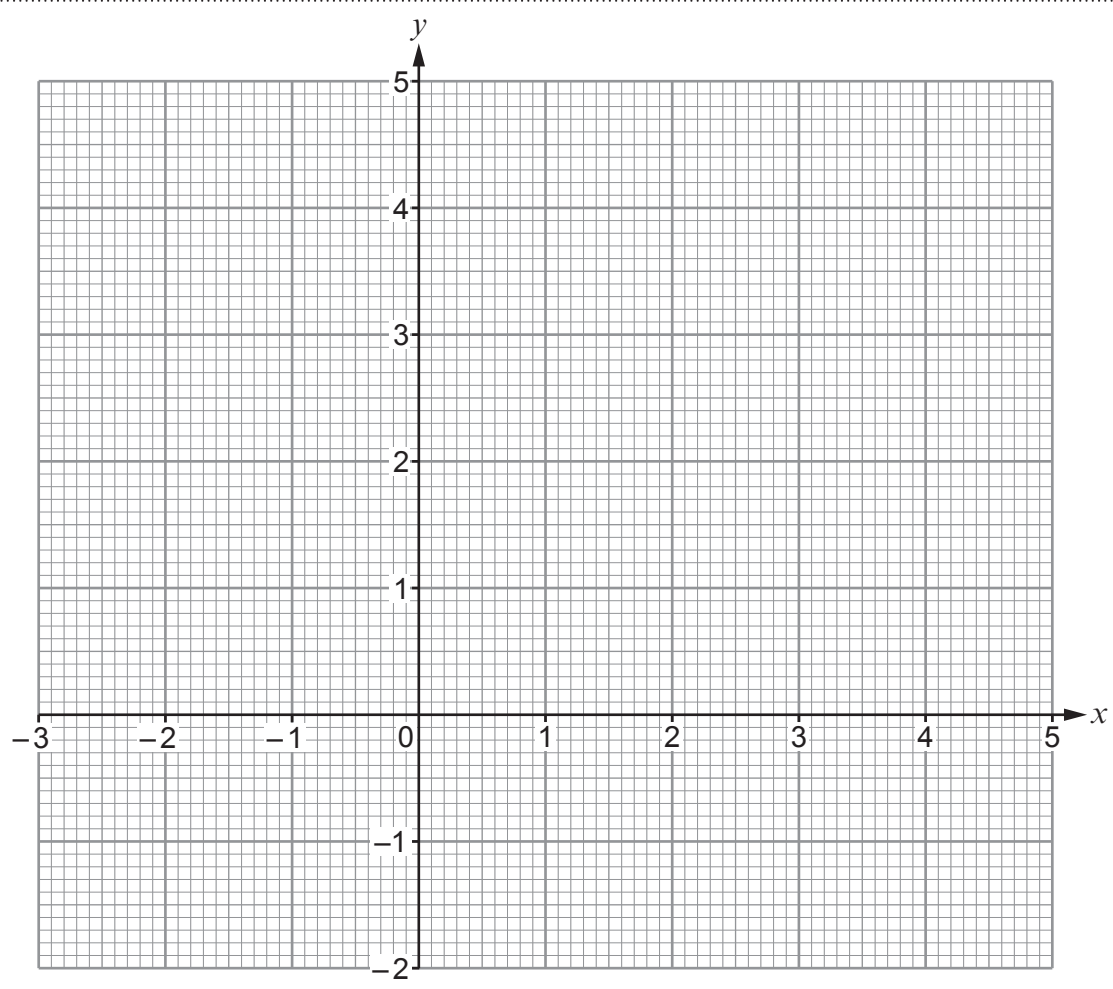

(b) (i) What is the **least** possible value of x so that all three conditions are met? [1]

$x = \dots\dots\dots$

(ii) What is the **greatest** possible value of y so that all three conditions are met? [1]

$y = \dots\dots\dots$



11. In a science experiment, Jamil collects the following pairs of data values for two variables, x and y .

x	4	7	8
y	80	245	320

- (a) Using the values in the table, show that y is **not** directly proportional to x . [2]

.....

.....

.....

.....

- (b) Given that y is directly proportional to x^2 , find a formula for y in terms of x . [3]

.....

.....

.....

.....

.....

.....



13. Prove that $(8n+1)^2-3$ is always an even number, for all integers n .
You must use an algebraic method.

[3]

.....

.....

.....

.....

.....

.....

.....

.....

.....

.....

.....

.....

.....

.....

.....

.....

.....

.....

.....

.....

.....

.....

14. Evaluate $\left(\frac{4}{3}\right)^{-1} + 16^{-\frac{3}{4}}$.

[3]

.....

.....

.....

.....

.....

.....

.....

.....

.....

.....

.....

.....

.....

.....

.....

.....

.....

.....

.....

.....

.....

.....



15. Simplify the following expression.

[4]

Examiner
only

$$(5 + \sqrt{3})(1 - \sqrt{3}) - (\sqrt{3})^5$$

.....

.....

.....

.....

.....

.....

.....

.....

.....

.....

.....

.....

.....

.....

.....

.....

.....

.....

.....

.....

.....

.....

.....

16. Simplify $\frac{16c^2 - d^2}{8c^2 + 2cd}$.

[4]

.....

.....

.....

.....

.....

.....

.....

.....

.....

.....

.....

.....

.....

.....

.....

.....

.....

.....

.....

.....

.....

.....



Examiner
only

17. Megan is a netball player.

She repeatedly attempts to throw the ball through the net.

On each throw, the probability that Megan gets the ball through the net is 0.7.
Each throw is independent of any previous throw.

Megan claims that the probability of getting the ball through the net for the first time on either the first or second throw is greater than 90%.

Is Megan correct?

Yes No

You must show all your working. [3]

.....

.....

.....

.....

.....

.....

.....

.....

.....

.....

.....

.....

.....

.....

.....

.....

.....

.....

.....

.....

.....

.....

.....



18. The following diagram shows a sketch of $y = \cos x$ for values of x from 0° to 360° .

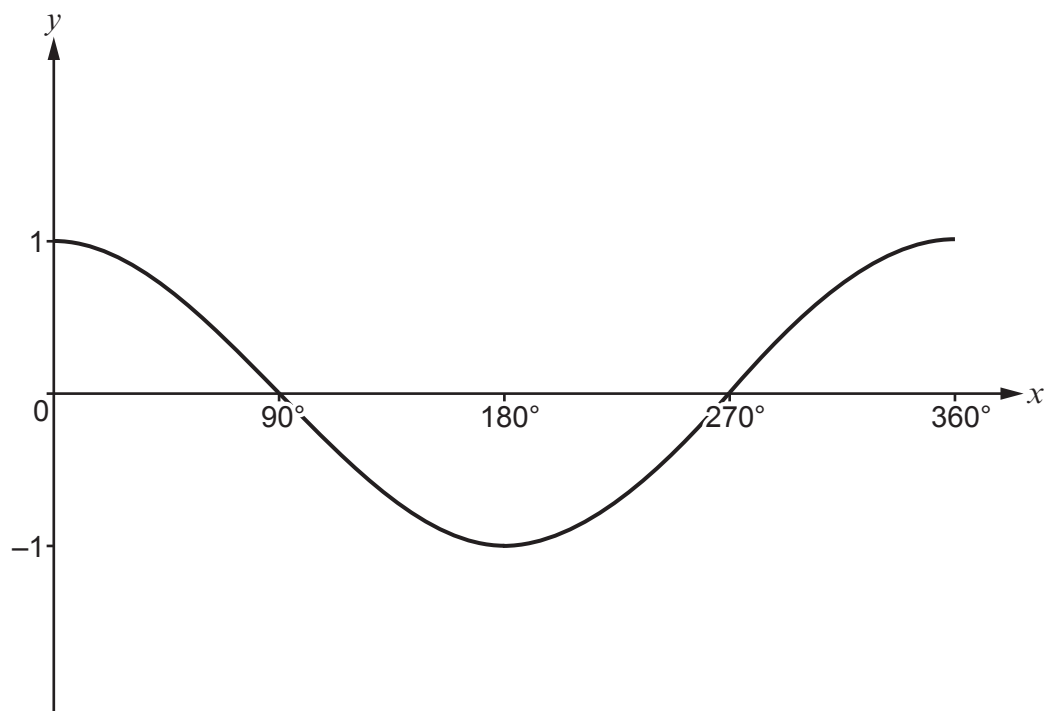

- (a) Given that $\cos 58^\circ = 0.5299$, correct to 4 decimal places, write down all the solutions of the equation

$$\cos x = -0.5299$$

for values of x from 0° to 360° .

[2]

.....

.....

.....

.....

.....

.....

.....

.....

.....

.....



- (b) (i) Use the following axes to sketch the graph of $y = 2 \cos x$ for values of x from 0° to 360° .
You must indicate any important values on the y -axis. [2]

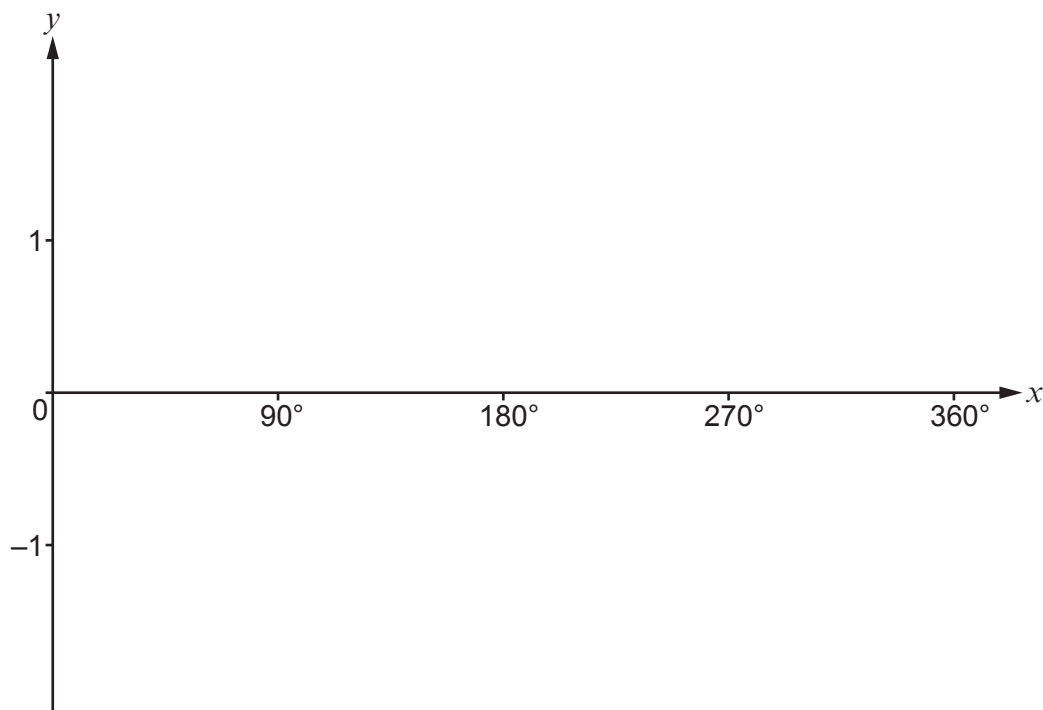

- (ii) Use the following axes to sketch the graph of $y = -\cos x$ for values of x from 0° to 360° .
You must indicate any important values on the y -axis. [2]

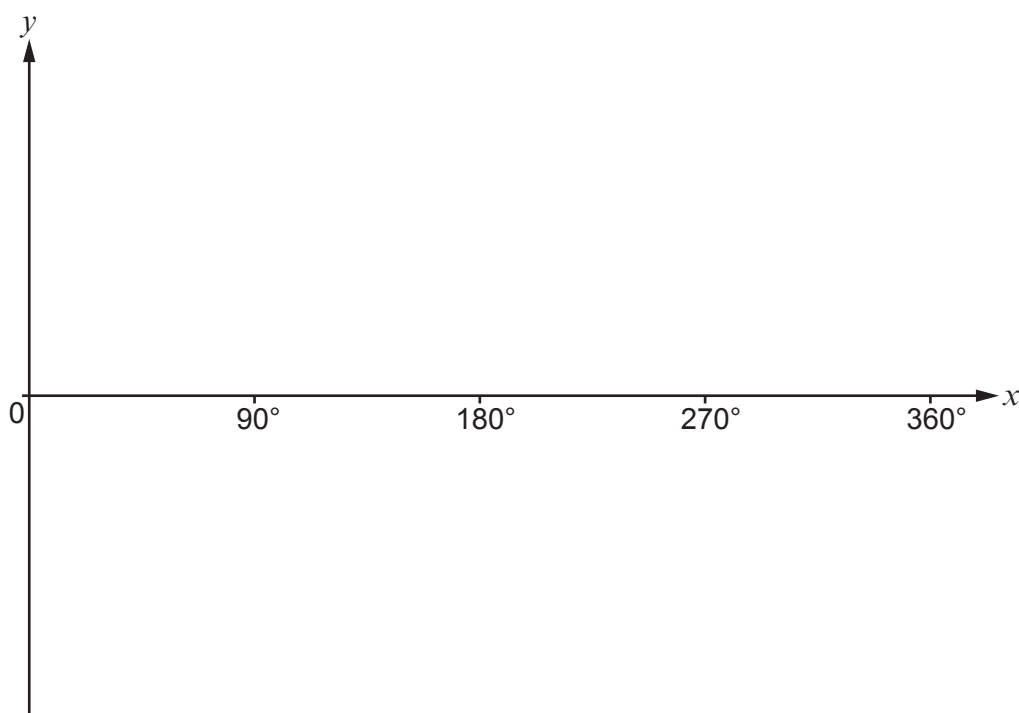
**END OF PAPER**

